

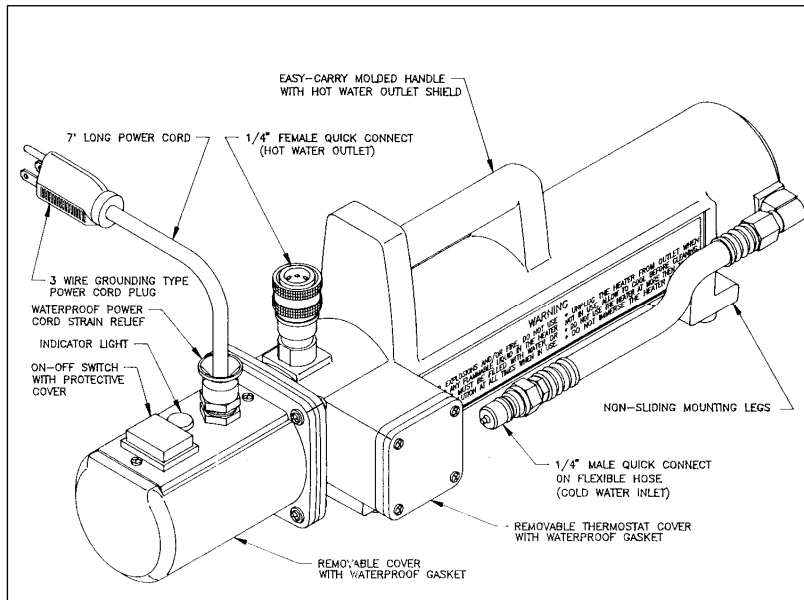

Heat 'N' Run

EXTERNAL IN-LINE HEATER FOR STEEMPRO 2000



SAFETY, OPERATION & MAINTENANCE INSTRUCTIONS

MODEL: AC3001 (UK / EC)
601HRP (USA)

CAUTION – READ THE INSTRUCTION MANUAL BEFORE USING THE APPLIANCE



EQUIPMENT DATA

MODEL NO.	AC3001
SERIAL NO.	
DATE OF PURCHASE	
DISTRIBUTOR NAME	
DISTRIBUTOR TEL NO.	
MANUFACTURER CONTACT	Prochem Europe Ltd. Oakcroft Road, Chessington, Surrey KT9 1RH, UK Telephone: + 44 (0)20 8974 1515 Fax: + 44 (0)20 8974 1511 Email: sales@prochem.co.uk Website: www.prochem.co.uk

All information and specifications in this manual are current at the date of issue. However, because of Prochem Europe policy of continual product improvement, we reserve the right to make changes at any time without notice. Please note that this manual applies to all models and explains variations including accessories used. Therefore, you may find some explanations for variations and options not installed on your equipment.

CONTENTS

	PAGE NO.
WARRANTY	5
IMPORTANT SAFETY INSTRUCTIONS	6
IMPORTANT OPERATING INSTRUCTIONS	7
GENERAL OPERATING INSTRUCTIONS	8
GENERAL MAINTENANCE	9
PARTS DIAGRAM	10
PARTS LIST	11
WIRING DIAGRAM	12
CE DECLARATION OF CONFORMITY	13

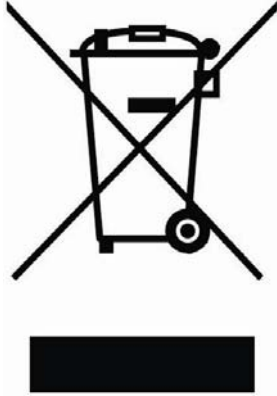

This product is marked according to the **European Directive (2002/96/EC) on Waste Electrical and Electronic Equipment (WEEE)**.

The symbol on this product indicates that this product must not be disposed of with normal household waste. Please protect human health and the environment by disposing of this product responsibly in the correct manner.

For further information regarding the disposal, treatment, recycling and recovery of this product, please contact:

Prochem Europe Sales Department
Telephone: +44 (0)20 8974 1515

Prochem Europe Ltd. EEE Producer Registration Number: WEE / AJ0044SY

European Directive (2002/95/EC) Restriction of use of certain Hazardous Substances in Electrical and Electronic Equipment (RoHS).

This equipment does not contain more than the maximum permitted levels by weight of the following substances:

Lead (Pb), Mercury (Hg), Cadmium (Cd), Hexavalent Chromium (Cr (VI)), Polybrominated Biphenyls (PBB), Polybrominated Diphenyl Ethers (PBDE)

WARRANTY

DATE EFFECTIVE: 1/1/12

As of the above date, this warranty supersedes all previous warranties and forms part of the contract of sale. Prochem Europe Ltd. (hereafter referred to as "Prochem") guarantees this machine to be free from defects in materials and workmanship for the relevant time period as shown below, and from the actual date of purchase by the user. Proof of the purchase date from a Prochem Authorised Distributor will be required for performance of this warranty.

Rotationally moulded polyethylene tanks2 Years
All other parts except maintenance items (see below)1 Year

THIS WARRANTY EXCLUDES NORMAL MAINTENANCE ITEMS, including but not limited to HOSES, FILTERS, O-RINGS, DIAPHRAGMS, VALVES, DRIVE BELTS, GASKETS, CARBON BRUSHES and damage to motors and other components as a result of failure to replace normal maintenance items. THIS LIST IS NOT EXHAUSTIVE.

To obtain performance of this warranty, contact the Prochem Authorised Distributor who supplied the product.

The Prochem Authorised Distributor is responsible as the selling agent for the provision of initial training in the correct use and application of the machine and approved chemicals. The distributor is also responsible for service maintenance and repairs during and after the warranty period and the administration of any warranty claims in conjunction with the Prochem Service Department. Failure of any of these provisions and responsibilities may invalidate the warranty and the authorised status of the distributor.

If Prochem receives notice of any defects during the warranty period, Prochem reserves the right to either repair, or replace components that prove to be defective. Goods must be returned before the warranty is approved. Goods sent out prior to the return of faulty items will be invoiced at current prices, subject to standard payment terms (see Prochem Standard Terms and Conditions of Sale). Replacement parts supplied under warranty will be guaranteed for the remainder of the original machine warranty and **NOT** from the date of installation. Spare parts supplied after expiry of machine warranty may be covered by a manufacturer's warranty, subject to inspection by Prochem Europe Ltd. and at its sole discretion. Normal maintenance items, however, are not covered. Replacement or credit of any returned parts will be at the discretion of the Prochem Service Department. Any subsequent refusal to accept their decision will serve to invalidate this warranty with immediate effect.

PROCHEM AUTHORISED DISTRIBUTORS are responsible for machine and accessories service back up during and after the warranty period. Prochem will furnish parts if the warranty is approved, but **DISTRIBUTORS** will be responsible for fitting, service, labour and related charges including travel, if applicable, and the cost of returning the machine or parts to Prochem. If any chargeable work is undertaken by Prochem for **DISTRIBUTORS** the labour, parts (if applicable) and return carriage will be charged at **FULL LIST PRICE**. If warranty is approved due to genuine manufacturing defect, then labour charges and return carriage charges may be waived at Prochem's discretion.

Prochem may send replacement parts to customers supplied by a **DISTRIBUTOR** or directly by Prochem, subject to the same conditions of replacement and payment above. The customer, however, will be responsible for fitting, labour and the carriage costs of returning repaired parts. Alternatively, Prochem will undertake warranty work at Chessington, subject to the same conditions, but the customer will be responsible for all carriage charges.

Any of the following circumstances involving the machine will serve to invalidate this warranty:-

NORMAL WEAR, ACCIDENTS, USE OF THE MACHINE FOR A PURPOSE OTHER THAN THAT FOR WHICH IT WAS INTENDED, INCORRECT MAINTENANCE, THE USE OF CHEMICALS OTHER THAN THOSE SUPPLIED OR APPROVED BY PROCHEM, INCORRECT INSUFFICIENT OR NON-USE OF DEFOAMER, EXPOSURE TO EXTREME TEMPERATURES OR CONDITIONS, INCORRECT INSTALLATION OR REPAIR & UNAUTHORISED INTERVENTION.

Liability is excluded for the following:-

All forms of damage and special damage founded in tort (apart from death and personal injury) and contract law including but not limited to consequential loss, loss of income and losses incurred in reliance of the contract; service, labour or third party charges and the cost of returning the machine or defective parts to Prochem or Prochem's Authorised Distributor.

As against a person dealing as a consumer, this warranty creates specific rights in addition to any statutory rights, which are unaffected. As against a person dealing otherwise than as a consumer, however, this warranty excludes any implied term that the machine will correspond with a description or a product sample.

With the exception of some specific products which are labelled and intended to be used by a consumer, all equipment, machinery, accessories, products, services and advice supplied by Prochem is intended for professional and industrial use only.

Your Prochem unit is designed to give you many years of reliable service. If a problem should arise during or after the warranty period, contact the Prochem Authorised Distributor or the Prochem Service Department, for details of the services available. Only the original purchaser of the new equipment may seek performance of this warranty – these rights cannot be transferred to a third party.

Prochem Europe Ltd.

Oakcroft Road, Chessington, Surrey KT9 1RH, ENGLAND

Telephone: + 44 (0)20 8974 1515 Fax: + 44 (0)20 8974 1511

Machine Warranty Issue 8 1/1/12

IMPORTANT SAFETY INSTRUCTIONS

**PLEASE READ THE FOLLOWING IMPORTANT SAFETY INSTRUCTIONS (!!)
BEFORE ATTEMPTING TO USE THIS EQUIPMENT. FAILURE TO OBSERVE
THE INSTRUCTIONS MAY RESULT IN PERSONAL INJURY.**

!! CAUTION

Read the instruction manual before using the appliance.

!! USE ONLY WITH STEEMPRO 2000

The Heat N Run unit has been designed for sole use with the Prochem Steempro 2000 carpet soil extraction machine fitted with pressure relief valve and high pressure solution hose. Do not attempt to use the Heat N Run with any other machine, solution hose or accessory attachment not recommended by the manufacturer.

!! APPLIANCE SUITABILITY

This appliance is suitable for commercial use, for example, in hotels, schools, hospitals, factories, shops, offices and rental businesses. Do not use the unit for other than the intended use.

This appliance is not intended for use by persons (including children) with reduced physical, sensory or mental capabilities, or lack of experience or knowledge, unless they have been given supervision or instruction concerning use of the appliance by a person responsible for their safety.

!! CHILDREN should be supervised to ensure they do not play with the appliance

!! UNPLUG FROM MAINS when not in use or during cleaning and maintenance – the plug is to be removed from the outlet socket.

!! TRAINING

You must be trained in the operation of this unit before use. Please read this manual carefully and obtain operating instruction from your Prochem Distributor or authorised representative in the correct use of this equipment.

!! REPAIRS

Should any repairs, including supply cord replacement be required, we recommend that the appliance be returned to an authorised dealer.

!! ELECTRICAL CABLE INSPECTION & REPLACEMENT

This unit must be earthed while in use to protect the operator from electric shock. It is equipped with a sealed and approved EC three conductor cable and three-prong 13A plug. If the supply cord is damaged it must be replaced by a special cord or assembly available from the manufacturer or its service agent. During operation a hazard may occur when running the machine over the power supply cord. Regularly examine the supply cord for damage, such as cracking or ageing. If damage is found replace the cord before use.

!! RCD CIRCUIT BREAKER

In common with other household and commercial electrical equipment, an 'RCD' circuit breaker plug device is strongly recommended for this type of equipment.

!! EXTENSION CABLES

Avoid using extension cables with this unit. If an extension cable is used it should be of a suitable rating, fully uncoiled and no longer than 30 metres. Use only three wire CE approved extension cable with CE approved three-prong earthed plugs and three pole receptacles that accept the unit's 13 amp plug.

!! DO NOT use a multiple adaptor socket to connect the machine and the heating unit or other devices to a single extension cable.

!! DO NOT immerse unit, cord or plug in water or other liquid to operate such as during flood extraction. Do not mount the unit over a bucket or sink. **SERIOUS INJURY OR DEATH MAY RESULT IF UNIT IS IMMERSSED IN WATER!**

!! DO NOT pull the unit by the cable or hoses.

!! DO NOT place the unit on or let the power cord contact any heated surface.

!! DO NOT use the unit with or near solvents or any flammable liquid or vapours. The heating unit can ignite flammable vapours such as fuels, solvents or thinners.

!! DO NOT operate the unit unless it is completely assembled.

!! DO NOT attempt repairs or maintenance unless you are suitably qualified or experienced. Repairs and maintenance should only be performed by qualified personnel and the unit should be tested for electrical safety before re-use.

!! SPRAY LIQUID ejection could be hazardous as a result of its temperature, pressure or chemical content.

!! IF LIQUID comes from the unit switch off immediately.

!! ALWAYS disconnect unit from mains supply when left unattended.

!! DURING USE UNIT MAY BECOME HOT. Do not touch hot surfaces. Use handle. Allow to cool before maintenance or cleaning. Close supervision is necessary when unit is used near children.

IMPORTANT OPERATING INSTRUCTIONS

PLEASE READ THE FOLLOWING IMPORTANT OPERATING INSTRUCTIONS (!) BEFORE ATTEMPTING TO USE THIS UNIT. FAILURE TO OBSERVE THE INSTRUCTIONS MAY RESULT IN DAMAGE TO THE EQUIPMENT.

! DO NOT use the unit outdoors. The unit is designed for indoor use only.

! DO NOT expose the unit to rain or freezing temperatures. Drain solution and store indoors when not in use.

! DO NOT operate the unit unless it is connected to the Steempro extraction machine.

! DO NOT use the unit with boiling water or temperature in excess of 95°C.

! DO NOT operate the unit at more than 300psi (20.7 bar) unless in conjunction with the special high pressure hoses supplied with the Steempro Powerplus 500 model.

! DO NOT use chemicals in the unit other than those manufactured or recommended by Prochem Europe.

! DO NOT operate the unit with a damaged power cord or plug, or after the unit malfunctions, or has been damaged in any manner. Return the unit to your authorised dealer or to Prochem Europe Service Department for examination, repair or adjustment.

! DO NOT attempt to repair the unit while it is under warranty. Contact your authorised dealer or Prochem Europe Service Department.

! DO NOT run the solution pump and heating unit dry. The unit must be filled with water based solution at all times when in use. Always switch off and disconnect the unit electrical supply when re-filling with solution.

! ALWAYS use a clean bucket to fill the solution tank of the Steempro machine to which the unit is attached.

! AFTER USE flush solution system and unit with clean water.

! ALWAYS observe directions and safety precautions on chemical products.

! USE ONLY genuine replacement parts for this unit, supplied by an authorised Prochem Distributor.

! DO NOT use this unit for any purpose other than for its intended design function. Any deviation from its proper use or purpose and any consequential damage that may occur is the sole responsibility of the user.

GENERAL OPERATING INSTRUCTIONS

BEFORE OPERATING THE UNIT

Read this manual carefully and completely before attempting to operate the unit. This manual has important information for the use and safe operation of the unit and should be kept available at all times. This equipment will ensure years of satisfactory service if operated and maintained according to recommendations in this manual. If additional help or information is needed, please contact your distributor or Prochem Europe Ltd.

FAILURE TO OBSERVE THESE INSTRUCTIONS MAY SERIOUSLY AFFECT THE PERFORMANCE OF THE UNIT AND INVALIDATE THE WARRANTY

IMPORTANT

The Prochem Heat N Run unit is designed only for use with the Steempro carpet soil extractor and 300psi high pressure solution hose. During use the unit will generate high temperatures and high pressure that will require the operation of the internal pressure relief valve system that is fitted as standard to all Steempro machines. If the unit is used in isolation or with other types of equipment it is possible that high heat and pressure build-up may damage hoses, equipment or cause personal injury.

OPERATING INSTRUCTIONS

(Refer to illustration on page 10)

- Make sure that the Heat 'N' Run is plugged into an electrical outlet with the same voltage rating as shown on the nameplate of the unit. Do not attempt to plug a 120 volt unit into a 230 volt outlet.
- Connect the Heat 'N' Run to the fitting plate on the rear of the Steempro machine. Connect the cold water inlet hose of the unit to the machine outlet connector. Connect the high pressure solution hose from the cleaning wand to the hot water outlet on the unit (see illustration on parts list page.)
- Before plugging in the unit power cord, run cleaning solution through the Heat 'N' Run to fill the heater chamber. Do this by connecting all hoses as described above, including the cleaning wand and turn on machine pump so that cleaning solution can be sprayed from the wand.
- Plug the cord into a circuit separate from any other appliance. Turn heater switch to the "On" position. The switch becomes illuminated and the indicator light goes "on". Within two minutes, the indicator light will go out, and the operating temperature, 80°C - 90°C (176°F - 194°F), will be reached. The switch will remain illuminated.
- If used with a carpet cleaning wand with 0.8 GPM jet at 70 to 100psi with a spraying cycle of 10 seconds running and 10 seconds waiting, the operating temperature for a 240 volt unit is 55°C (131°F) when water at 20°C (68°F) is used. When hot water at 60°C (140°F) is used, the operating temperature will be 85°C (185°F).
- Cool the unit before disconnecting from the line. Turn the switch "Off". Disconnect the electrical cord and run cold water through the unit for 20 to 30 seconds.
- During use, with power to the unit, the switch and the indicator light are illuminated. If cleaning is not taking place (no water flowing through the unit) the solution inside the heater tank may reach 95°C (203°F) and the indicator light will go out. If left unattended the pressure increase will be discharged via the internal relief valve in the Steempro machine.
- Turn power switch off and charge the unit with solution up to the wand, then turn the heater switch on. Approximately 20 seconds after pre-heating, start cleaning.
- If not in use, turn heater off by using illuminated switch. If the unit is left on for long periods while not in use, the high heat thermostat will cut in and it will take approximately 1 minute with constant flow to return to normal heating mode.
- When, for any reason, water in the heater tank is overheated to 100°C (212°F) or more a built-in thermal switch cuts the heating element off. The heater switch, though in the "On" position, becomes unlit, and the Heat 'N' Run is no longer operational. This is a safety precaution feature. Cool the unit as described above and send it to your authorised dealer for resetting and testing.
- In the event of abnormal operation or thermostat failure, a secondary thermostat will shut the unit down. The unit should then be returned to your authorised distributor for inspection and repair.

GENERAL MAINTENANCE

All Prochem equipment is engineered and built to require a minimum of maintenance. But like any equipment, it does require some care to keep it in optimum working condition. Careful attention to these maintenance instructions will give you maximum operating performance and will increase the life expectancy of the machine. To ensure a trouble-free machine, we strongly advise the following preventative maintenance.

DAILY MAINTENANCE

The following should be carried out at the end of each cleaning session.

POWER CABLE & PLUG

Check the condition of the power cable and plug. Make sure all wires are correctly located and tightly connected. If damaged, the power cable and plug assembly must be replaced.

DO NOT ATTEMPT REPAIR.

Instruction for replacement of power cable with combined plug.

!! CAUTION - ONLY QUALIFIED MAINTENANCE PERSONNEL SHOULD ATTEMPT THE FOLLOWING REPAIR

Should the power cable require replacement, please follow the instructions below.

1. The replacement cable and plug shall be of the same specification as the original Prochem part number BE4901 (3 core 1.5mm with 13Amp sealed plug unit)
2. Ensure that the unit is disconnected from electrical supply and open electrical housing by means of tool required.
3. Disconnect the live (brown), neutral (blue) and earth (green/yellow) wires from the cable terminal block by means of unscrewing the terminal block wire clamp screws.

4. Unscrew the outer cable gland and cord anchor screw to release the cable which can then be pulled out of the cable gland assembly.
5. Insert the new cable through the cord anchor and cable gland and secure the outer cable by means of tightening the outer cable gland and the anchor securing screw.
6. Connect the live (brown), neutral (blue) and earth (green/yellow) wires to the cable entry gland terminal block by means of inserting the wire conductors into the terminal block as follows :-
The conductor of the wire coloured brown shall be connected to the terminal marked (L), the conductor of the wire coloured blue shall be connected to the terminal marked (N) and the conductor of the wire coloured green and yellow shall be connected to the terminal marked with the Earth symbol thus - 
7. Ensure that all connections are secure and close electrical housing and secure with tool required.

BODY AND FITTINGS

Inspect the outer body of the unit for signs of leakage or damage. Check tightness of all screws and security of hose connectors and hose fittings.

WARNING! FREEZING PROTECTION

If your unit is exposed to freezing weather with solution inside, the solution will **FREEZE** and in most cases **SERIOUSLY DAMAGE** the unit. To avoid damage, consider the following in the winter season. When the unit is not in use, store it in a **heated building**. To avoid freezing between jobs, pump out all the cleaning solution from the machine, Heat 'N' Run unit, wand and hand tool and make sure all equipment is insulated from the vehicle floor (wrap in a blanket or tarpaulin).

PARTS DIAGRAM

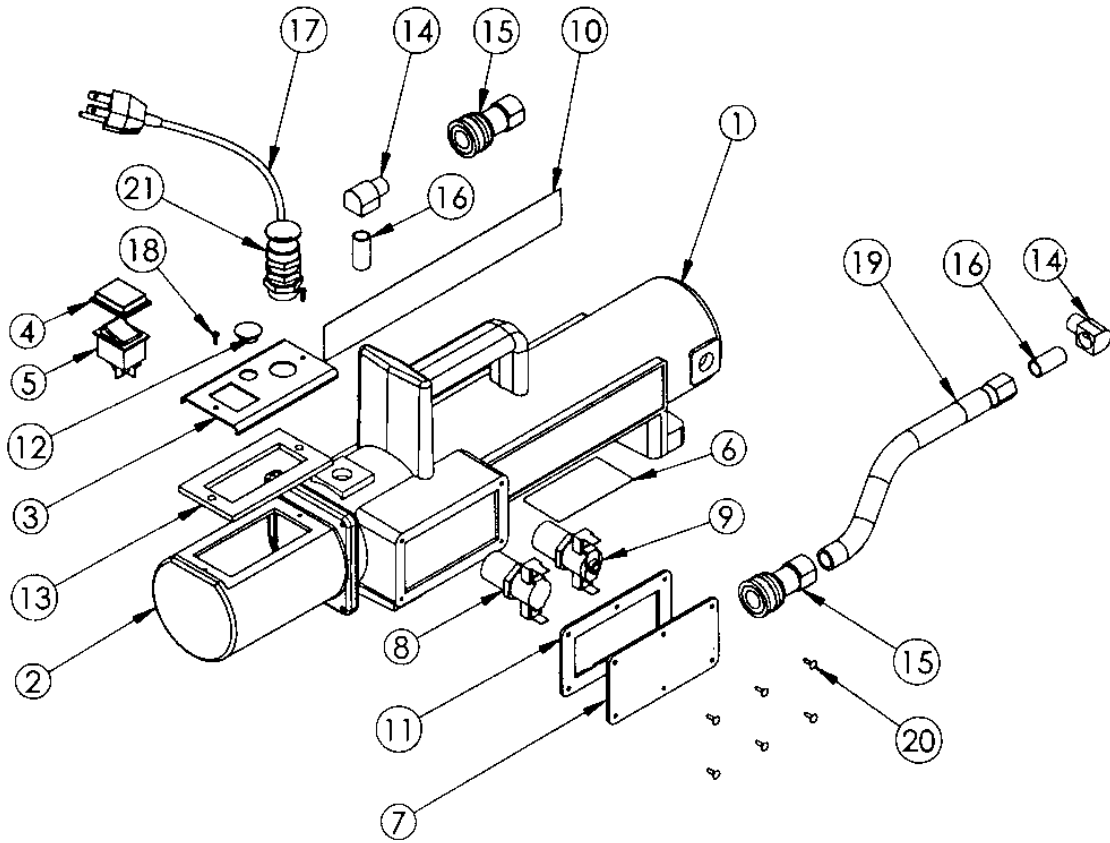

HEAT 'N' RUN PARTS LIST

REF.	STOCK CODE	PART NO.	DESCRIPTION	QTY
1		F11796	HEATER HOUSING	1
2		F11795	HEATER CAP	1
3		D11227	SWITCH PLATE	1
4	E00214-2	B00214-2	SWITCH COVER	1
5	E02211-1	B02211-1	ROCKER SWITCH	1
6		H00565-5	SERIAL NUMBER PLATE	1
7		D11254	THERMOSTAT COVER	1
8	E5004	G10964	THERMOSTAT 150 / 65	1
9	E11258	G11258	THERMOSTAT WITH BREAKER	1
10		H10960	WARNING LABEL	1
11		E11256	GASKET THERMOSTAT	1
12	E02196	B02196	INDICATOR LIGHT	1
13		E10941	GASKET SWITCH PLATE	1
14	E00052	A00052	90 DEGREE ELBOW	2
15	GU00102 GU00104	A00102	FEMALE QUICK CONNECT MALE QUICK CONNECT (NOT SHOWN)	1 1
16	CH00111	A00164	NIPPLE, 1/4" BRASS	2
17	BE4901	B02218	POWER CORD WITH PLUG UK EC	1
18		C00310-38	SCREW, 8-32 X 3/8 RH	1
19		80580A	HOSE ASSEMBLY	1
20		C11435	SCREW 6-32 X 3/8 FLATHEAD	6
21	E02213	B02213	STRAIN RELIEF	1
			PARTS NOT SHOWN ON DIAGRAM	
		11247A	TANK ASSEMBLY	1
		B02190	TERMINAL BLOCK	1
		B10933	WIRE HARNESS	1
		B11463	12 GA TEFLON WIRE	4
		B11761	TERMINAL LUG	2
		B11762	TERMINAL LUG	1
		F10956	PVC PARTITION	

WIRING DIAGRAM

MODEL AC3001 HEAT 'N' RUN
2800W 220/240V AC 50Hz

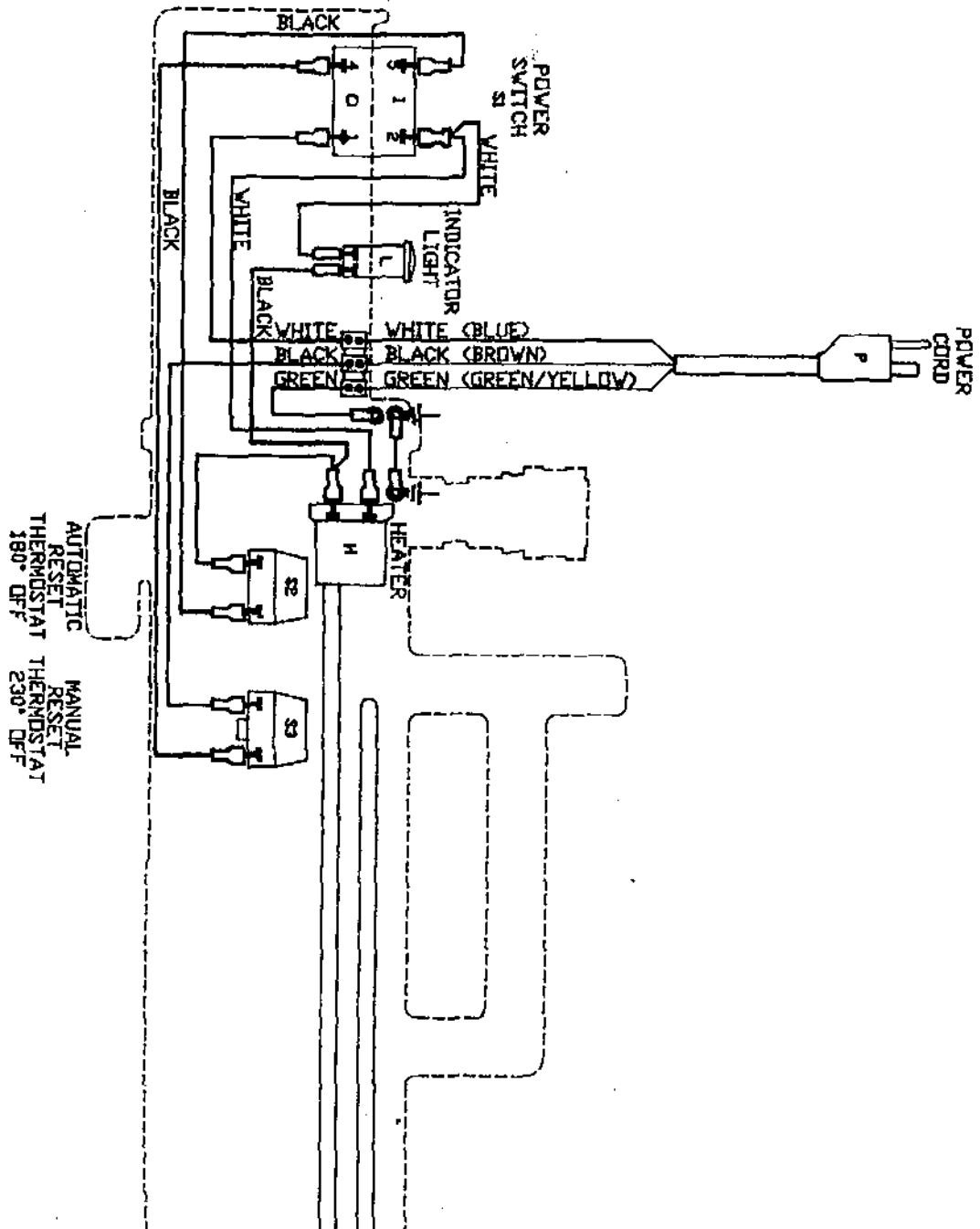

DECLARATION OF CONFORMITY

We:
Prochem Europe Ltd.,
Oakcroft Road,
Chessington,
Surrey, KT9 1RH
UK
(Importer / EC Responsible Person)

E.D.I.C
1753, Blake Avenue,
Los Angeles,
California, 90031-1006
USA
(Manufacturer)

Declare that the product(s):

Type(s): **HEAT 'N' RUN**
Model(s): **AC3001 / 601HRP**
Description: **HEATER UNIT 220 - 240V 50 Hz**

Have been manufactured in conformity with the following standards and specifications:

BS EN 60335-1: 2002 + A2: 2006
BS EN 60335-2-68: 2003 + A1:2006 + A2: 2007 + Corr: 2006
EN 55014-1: 2006
EN 55014-2: 1997 + A1: 2001 + A2: 2008
BS EN 61000-3-2: 2006
BS EN 61000-3-3: 2008

And comply with the requirements of (as amended):

2006/95/EC **Low Voltage (LVD) Directive**
2004/108/EC **Electromagnetic Compatibility (EMC) Directive**

A Technical file is held by Prochem Europe Ltd.

Certificate of compliance and test reports have been issued by:

SGS United Kingdom Ltd.
Unit 10, Bowburn South Industrial Estate
Bowburn, Durham DH6 5AD
Ref: DUR41944-2 & DUR41944/1/EMC/IH/04

Signed
(For and on behalf of the Importer / EC Responsible Person)

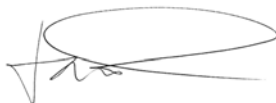

Name: J Hattersley
Position: Equipment Product Manager
Place of Issue: Chessington UK
Date of Issue: 1/9/2011